

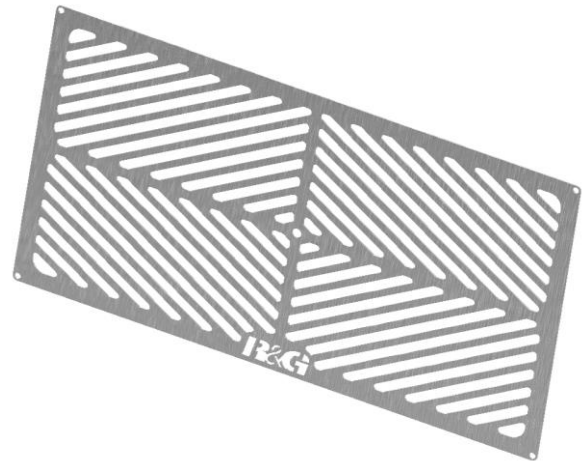

**FITTING INSTRUCTIONS FOR SRG0079 RADIATOR GUARD  
FOR YAMAHA XTZ 700 (TENERE) 2019-**



**PICTURE A**



**PICTURE B**

**THIS KIT CONTAINS THE ITEMS PICTURED AND LABELLED OVER PAGE.**

SOME PARTS MAY BE SHOWN FOR CLARITY OF INSTRUCTIONS ONLY.

DO NOT PROCEED UNTIL YOU ARE SURE ALL PARTS ARE PRESENT.

**PLEASE READ ALL INSTRUCTIONS BEFORE PROCEEDING.**

**IF IN ANY DOUBT WHEN FITTING OUR PRODUCTS, CONSULT ONE OF  
OUR DEALERS OR HAVE FITTED BY A QUALIFIED TECHNICIAN.**

PLEASE NOTE THAT THE WAY THE KIT IS PACKED DOES NOT NECESSARILY REPRESENT THE  
WAY OF MOUNTING TO THE BIKE.

IN THE EVENT OF RUBBER WASHERS BEING USED TO HOLD COMPONENTS ONTO BOLTS,  
THESE RUBBER WASHERS CAN BE THROWN AWAY.

**DIGITAL COPIES OF THESE INSTRUCTIONS ARE AVAILABLE FROM:**

[WWW.RG-RACING.COM](http://WWW.RG-RACING.COM)



<b><u>TOOLS REQUIRED</u></b>	<b><u>GENERAL TORQUE SETTINGS</u></b>
<ul style="list-style-type: none"> <li>• Socket set to include 8mm A/F and T30 sockets or spanners.</li> <li>• Set of metric Allen keys.</li> </ul>	M4 BOLT = 8Nm M5 BOLT = 12Nm M6 BOLT = 15Nm M8 BOLT = 20Nm M10 BOLT = 40Nm M12 BOLT = 40Nm

### **LEGEND**

ITEM NO.	DESCRIPTION	QTY
ITEM 1	STAINLESS RADIATOR GUARD (SS RAD0079)	1
ITEM 2	SELF ADHESIVE FOAM x 100mm LONG	4
ITEM 3	CABLE TIES (CT0220)	8



PICTURE 1



PICTURE 2



PICTURE 3

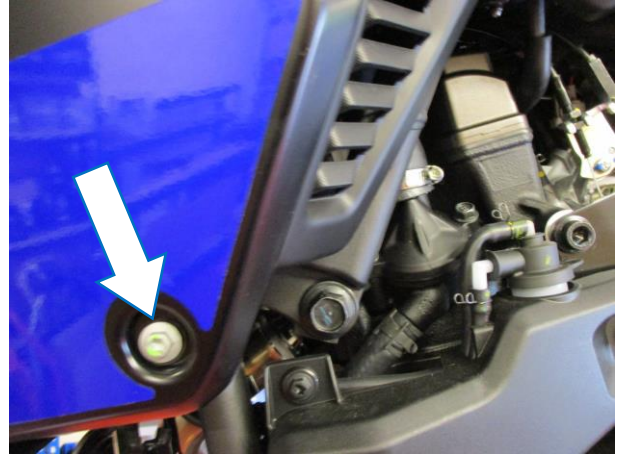

PICTURE 4

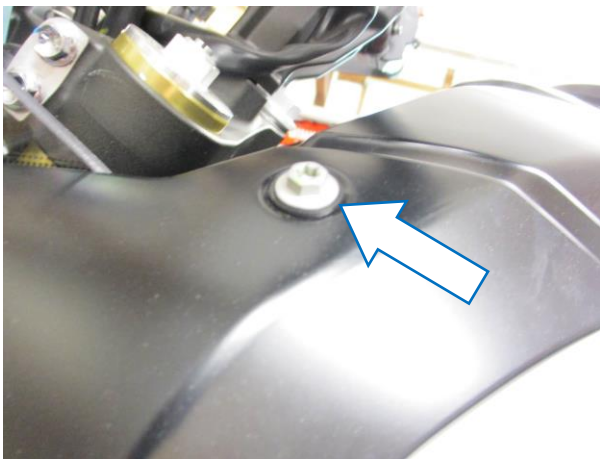

PICTURE 5



PICTURE 6

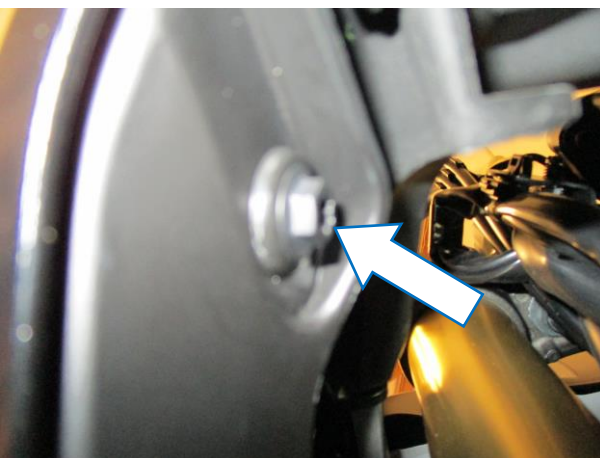

PICTURE 7



PICTURE 8



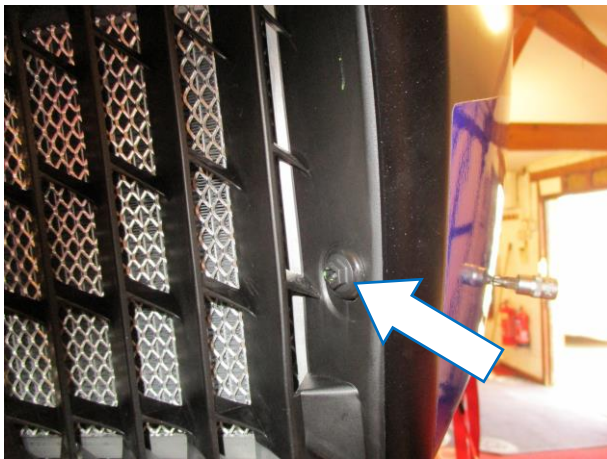

PICTURE 9

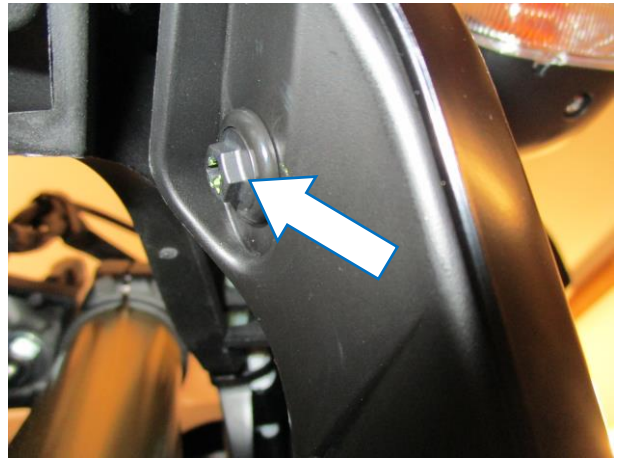

PICTURE 10

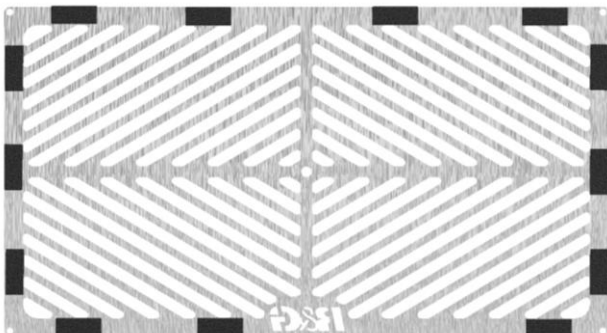

PICTURE 11

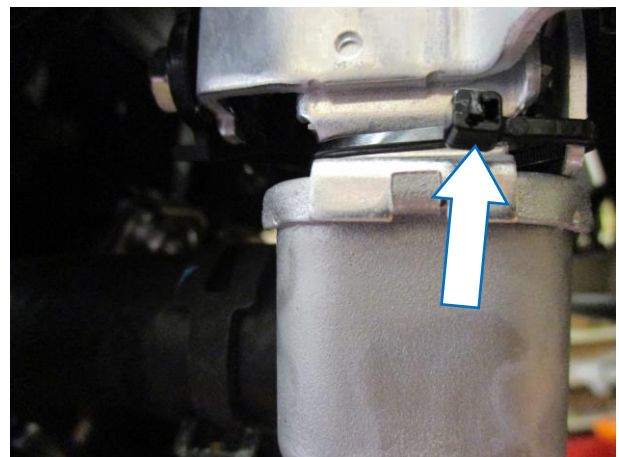

PICTURE 12

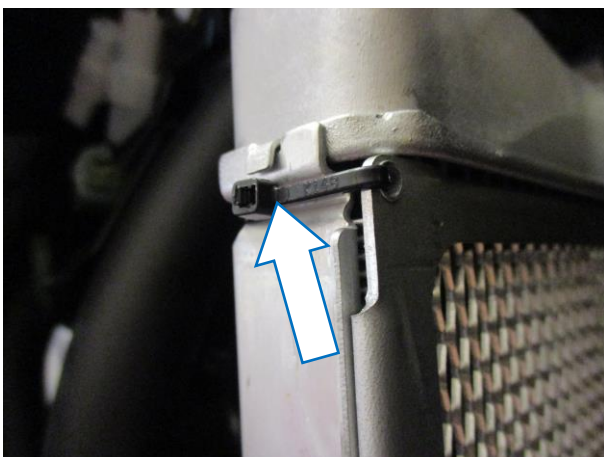

PICTURE 13

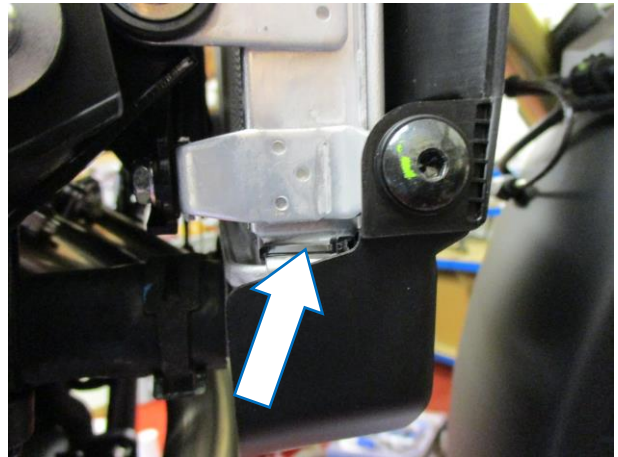

PICTURE 14

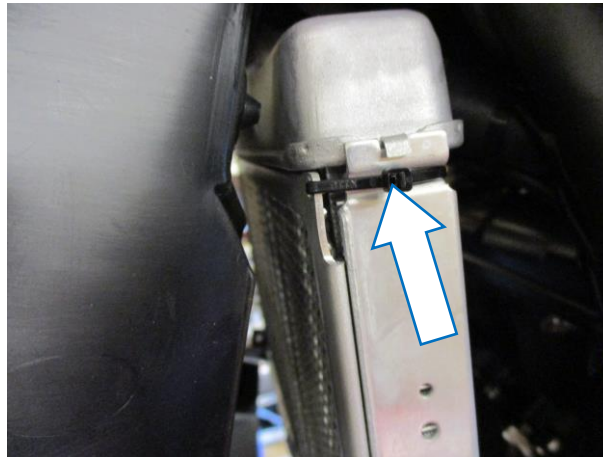

PICTURE 15

### **FITTING INSTRUCTIONS**

- Remove the three bolts arrowed in **pictures 1, 2 and 3**.
- Remove the three bolts arrowed in **pictures 4, 5 and 6** and remove both side fairings (ensuring to disconnect the indicators).
- Remove the ¼ turn plastic rivets arrowed in **pictures 7, 8, 9 and 10**, then remove the original radiator surround.
- To fit the radiator guard to the bike, first cut the self-adhesive foam strip provided (**item 2**) into 10mm wide pieces and stick them to the back of the radiator guard frame (**item 1**), so that they will sit between the radiator guard and the radiator as shown in **picture 11**.
- Offer the radiator guard into position and use the supplied cable ties to secure the guard into position as shown in **pictures 12, 13, 14 and 15** ensuring to pass the cable ties through the radiator frame and not the cooling matrix.
- Refit the original radiator surround and side fairings as original (ensuring to reconnect the indicators).

ISSUE 1 28/11/2019 (NSY)

### **CONSUMER NOTICE**

The catalogue description and any exhibition of samples are only broad indications of the Products and R&G may make design changes which do not diminish their performance or visual appeal and supplying them in such state shall conform to the order. The Buyer acknowledges no representation or warranty (other than as to title) has been given or will apply to the Products other than those in R&G's order or confirmation and the Buyer confirms it has chosen the Products as being of merchantable quality and suitable for its particular purposes. Where R&G fits the Products or undertakes other services it shall exercise reasonable skill and care and rectify any fault free of charge unless the workmanship has been disturbed. The Buyer is responsible for ensuring that the warranty on the motorcycle is not affected by the fitting of the Products. On return of any defective Products R&G shall at its option either supply a replacement or refund the purchase money but shall not be liable if the Products have been modified or used or maintained otherwise than in accordance with R&G's or manufacturer's instructions and good engineering practice or if the defect arises from accident or neglect. Other than identified above and subject to R&G not limiting its liability for causing death and personal injury, it shall not be liable for indirect or consequential loss and otherwise its liability shall be limited to the amounts paid by the Buyer for the Products or the fitting or service concerned. These terms do not affect the Buyer's statutory rights.

### **R&G RETURNS POLICY (NON-FAULTY GOODS)**

Returns must be pre-authorized (if not pre-authorized the return will be rejected). Goods may only be returned direct to us if they were purchased direct from us (customer must prove if necessary). Otherwise to be returned to original vendor. Goods must be in re-sellable condition, in the opinion of R&G. All returns are subject to a 25% restocking and handling fee (25% of the gross value exc. P&P – at the prevailing price at time of purchase). The customer must pay any and all carriage charges. No returns of discontinued products, unless within 14 days of purchase. This policy does not affect your statutory rights and does not refer to faulty goods.

R&G

Unit 1, Shelley's Lane, East Worldham, Alton, Hampshire, GU34 3AQ  
 Tel: +44 (0)1420 89007 Fax: +44 (0)1420 87301 [www.rg-racing.com](http://www.rg-racing.com) Email: [info@rg-racing.com](mailto:info@rg-racing.com)



**NOTICE DE MONTAGE POUR**  
**SRG0079 PROTECTION RADIATEUR**  
**POUR YAMAHA XTZ 700 (TENERE) 2019-**



**PHOTO A**

**LE KIT CONTIENT LES ARTICLES EN PHOTO ET ETIQUETTES SUR LA PAGE**

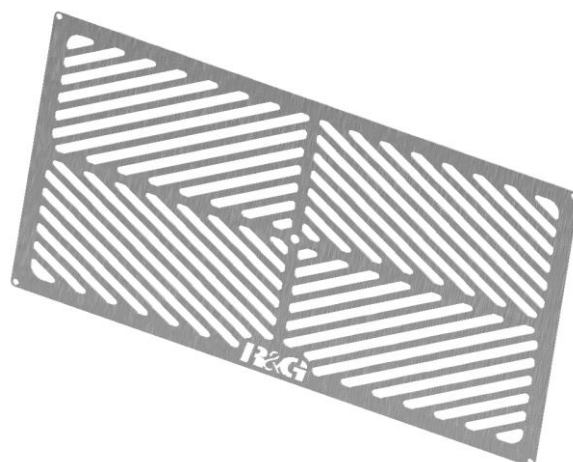

**PHOTO B**

**LES PARTIES PRESENTÉES PEUVENT ETRE UNIQUEMENT REPRESENTATIVES  
POUR LA CLARTE DES INSTRUCTIONS.**

**NE PAS PROCEDER AU MONTAGE AVANT DE VOUS ETRES ASSURE QUE TOUTES LES PIECES SOIENT PRESENTES.  
SVP, LIRE L'ENSEMBLE DE LA NOTICE AVANT DE PROCEDER AU MONTAGE.**

**EN CAS DE DOUTE LORS DU MONTAGE, CONSULTEZ UN DE NOS REVENEURS, OU  
FAITES EFFECTUER LE MONTAGE PAR UN TECHNICIEN QUALIFIE.**

LA FAÇON DONT LE KIT EST EMBALLE NE CORRESPOND PAS FORCEMENT A LA FAÇON DE  
MONTER LES PIECES SUR LA MOTO.

NOTEZ QUE SI LES KITS SONT EMBALLES AVEC DES RONDELLES EN CAOUTCHOUC  
SERVANT A TENIR LES COMPOSANTS, CES RONDELLES DOIVENT ETRE JETEES.

**NOTICE DISPONIBLE AU TELECHARGEMENT SUR :**  
[WWW.RG-RACING.COM](http://WWW.RG-RACING.COM)



<b><u>OUTILS REQUIS</u></b>	<b><u>VALEURS DE SERRAGE</u></b>
<ul style="list-style-type: none"> <li>• Clé à cliquet + douilles 8mm et T30.               <ul style="list-style-type: none"> <li>• Clés Allen</li> </ul> </li> </ul>	M4 BOULON = 8NM M5 BOULON = 12NM M6 BOULON = 15NM M8 BOULON = 20NM M10 BOULON = 40NM M12 BOULON = 40NM

### **LEGENDE**

<b>ARTICLE NO.</b>	<b>DESCRIPTION</b>	<b>QTE</b>
ARTICLE 1	PROTECTION RADIATEUR (SS RAD0079)	1
ARTICLE 2	MOUSSE AUTOCOLLANTE x 100mm	4
ARTICLE 3	COLLIERS DE SERRAGE (CT0220)	8

### **NOTICE DE MONTAGE**

- Retirez les trois boulons fléchés des photos 1, 2 et 3.
- Retirez les trois boulons fléchés des photos 4, 5 et 6 et retirez les deux carénages latéraux (en veillant à débrancher les clignotants).
- Retirez les rivets en plastique ¼ de tour marqués d'une flèche sur les photos 7, 8, 9 et 10, puis retirez le contour d'origine du radiateur.
- Pour installer la protection de radiateur sur la moto, commencez par couper la bande de mousse autocollante fournie (article 2) en morceaux de 10 mm de large, et collez-les au bas du cadre de la protection de radiateur (article 1) afin que les bandeaux se placent entre la protection de radiateur et le radiateur comme indiqué sur la photo 11.
- Placez la protection en place et utilisez les colliers de câble fournis pour la fixer, comme indiqué sur les photos 12, 13, 14 et 15, en veillant à faire passer les colliers dans le cadre du radiateur et non dans la matrice de refroidissement.
- Reposer les carénages latéraux et latéraux d'origine du radiateur comme à l'origine (en veillant à reconnecter les clignotants).

ISSUE 1 28/11/2019 (NSY)





**MONTAGEANLEITUNG FÜR SRG0079 KÜHLERSCHUTZ  
FÜR YAMAHA XTZ 700 (TENERE) 2019-**



**ABBILDUNG A**

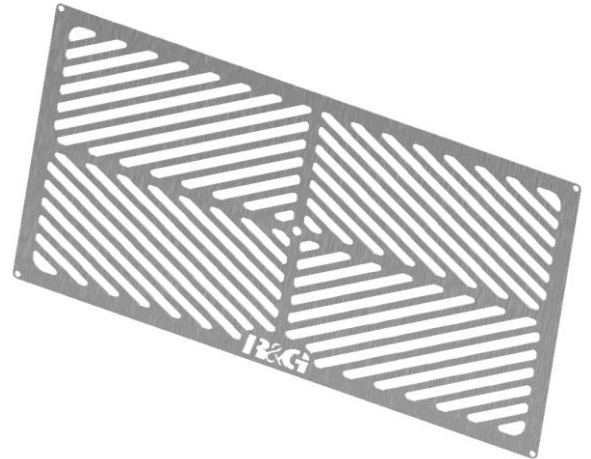

**ABBILDUNG B**

**ALLE KIT-TEILE SIND AUF DEN FOLGENDEN SEITEN ABGEBILDET UND GEKENNZEICHNET.**

DIE ABGEBILDETEN TEILE DIENEN LEDIGLICH ZUR ERKLÄRUNG.

ÜBERPRÜFEN SIE ZUERST, DASS ALLE TEILE VORHANDEN SIND.

**LESEN SIE DIE MONTAGEANLEITUNG KOMPLETT DURCH, BEVOR SIE ANFANGEN.**

**WENN SIE BEI DER MONTAGE DIESES PRODUKTES UNSICHER SIND,  
BITTE EINEN UNSERER HÄNDLER KONTAKTIEREN ODER DAS KIT VON  
EINEM QUALIFIZIERTEN ZWEIRAD-MECHANIKER MONTIEREN LASSEN.**

DIE VERPACKUNG DER TEILE STELLT NICHT DIE REIHENFOLGE DER MONTAGE DAR.

HINWEIS FÜR KITS MIT PLASTIKUNTERLEGSCHLEIBEN AN DEN SCHRAUBEN –  
DIESE PLASTIK-UNTERLEGSCHLEIBEN WERDEN NICHT FÜR DEN EINBAU BENÖTIGT!

**EINE DIGITALE VERSION DIESER MONTAGEANLEITUNG KANN AUF  
FOLGENDER SEITE HERUNTERGELADEN WERDEN:**

[WWW.RG-RACING.COM](http://WWW.RG-RACING.COM)





<p><b><u>SIE BENÖTIGEN FOLGENDES WERKZEUG:</u></b></p> <ul style="list-style-type: none"> <li>• Steckschlüsselsatz inkl. 8mm A/F und T30-Einsätze od. Schraubenschlüssel             <ul style="list-style-type: none"> <li>• Satz Inbusschlüssel</li> </ul> </li> </ul>	<p><b><u>ALLGEM. ANZUGSDREHMOMENTE</u></b></p> <p>M4 SCHRAUBE = 8Nm  M5 SCHRAUBE = 12Nm  M6 SCHRAUBE = 15Nm  M8 SCHRAUBE = 20Nm  M10 SCHRAUBE = 40Nm  M12 SCHRAUBE = 40Nm</p>
--	---

## **LIEFERUMFANG**

ARTIKEL-NR.	BESCHREIBUNG	MENGE
ARTIKEL 1	EDELSTAHL KÜHLERSCHUTZ (SS RAD0079)	1
ARTIKEL 2	SELBSTKLEBENDE SCHAUMSTOFFSTREIFEN 100mm LÄNGE	4
ARTIKEL 3	KABELBINDER (CT0220)	8

## **MONTAGEANLEITUNG**

- Entfernen Sie die drei Schrauben, die in den **Abbildungen 1, 2 und 3** mit Pfeilen gekennzeichnet sind.
- Entfernen Sie die drei Schrauben, die in den **Abbildungen 4, 5 und 6** mit Pfeilen markiert sind und entfernen Sie beide Seitenverkleidungen (bitte die Blinker trennen).
- Entfernen Sie die Plastiknieten, die in den **Abbildungen 7, 8, 9 und 10** gekennzeichnet sind und entfernen Sie das original Verkleidungsteil für den Kühler.
- Um den Kühlerschutz am Montieren zu können, schneiden Sie zuerst die mitgelieferten Schaumstoffstreifen (**Artikel 2**) in 10 mm breite Streifen und kleben Sie diese auf der Rückseite des Kühlerschutzrahmens (**Artikel 1**), so dass sie zwischen dem Kühlerschutz und dem Kühler angebracht sind wie in **Abbildung 11** abgebildet.
- Den Kühlerschutz in Position bringen und mit den Kabelbindern vom Kit fixieren wie in den **Abbildungen 12, 13, 14 und 15** abgebildet. Bitte achten Sie darauf, dass Sie die Kabelbinder durch den Kühlerahmen fädeln und nicht durch das Gitter des Kühlerschutz.
- Montieren Sie das original Verkleidungsteil für den Kühler und die Seitenverkleidungen wie ursprünglich wieder (bitte auch die Blinker wieder anschließen).

AUSGABE 1 28/11/2019 (NSY)

R&G

Unit 1, Shelley's Lane, East Worldham, Alton, Hampshire, GU34 3AQ  
 Tel: +44 (0)1420 89007 Fax: +44 (0)1420 87301 [www.rg-racing.com](http://www.rg-racing.com) Email: [info@rg-racing.com](mailto:info@rg-racing.com)